

RITEN USA FACE DRIVERS INFORMATION REQUEST

The following technical information is needed to determine your face driver requirements. Please complete and fax to Riten at 1-800-338-0717. If you have any questions please phone our customer service department by calling 1-800-338-0027.

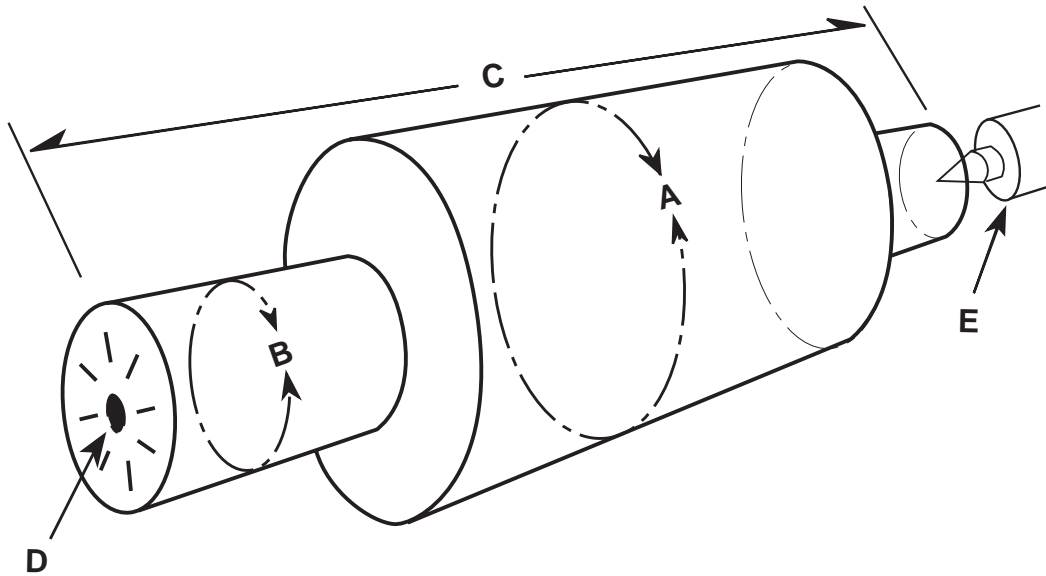

MOUNTING DATA

Morse Taper: _____
 Chuck Mount: _____
 Flange Mount: _____
 Spindle Size if Flange Mounting: _____
 Spindle Rotation: Clockwise Counterclockwise Both

WORKPIECE DATA

Workpiece Name (description): _____

A. Beginning Diameter: _____	• Material Type: _____
B. Finished Diameter: _____	• Material Hardness: Rc _____ BHN _____
C. Overall Length of Workpiece: _____	• Workpiece Weight: _____
D. Center Hole Diameter: _____	• Concentricity to Achieve: _____
E. Center: Live _____ Dead _____	• Maximum Tailstock Ability Force (lbs.): _____

Please attach finished part print to this application data request sheet.

OPERATION

Maximum Depth of Cut: _____
 Feed/Revolution: _____
 Cutting Speed (inch/rev.): _____
 RPM: _____
 Are there simultaneous operations? (check one): Yes No

MACHINE DATA

Machine Type: _____
 Machine Manufacturer: _____
 Machine Size: _____
 Tool Holder: Left Right
 Machining Conditions (check one): Very Good Good Acceptable Bad