

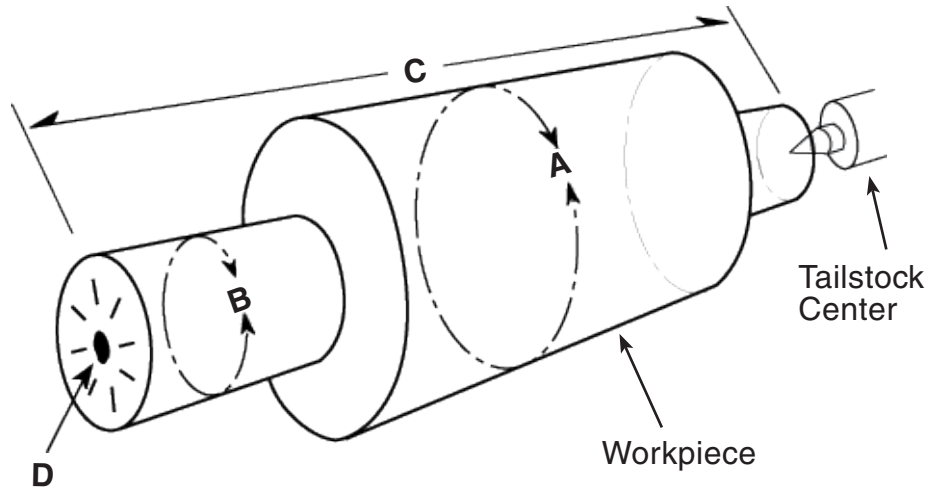

# Information Request

The following technical information is needed to determine your face driver requirements. Please complete and fax to Riten at 1-800-338-0717. If you have any questions please phone our customer service department at 1-800-338-0027.



## Face Driver Mounting Data

Type of mount (check one):  Flange mount  Chuck mount  Taper mount  Other \_\_\_\_\_

If flange mount (check one):  A2-5  A2-6  A2-8  A2-11  Other \_\_\_\_\_

If taper mount (check one):  3 MT  4 MT  5 MT  6 MT  Other \_\_\_\_\_

## Workpiece Data

Workpiece Name (description): \_\_\_\_\_

A Beginning Diameter: \_\_\_\_\_ • Material Type: \_\_\_\_\_

B Finished Diameter: \_\_\_\_\_ • Material Hardness: Rc \_\_\_\_\_ BHN \_\_\_\_\_

C Overall Length of Workpiece: \_\_\_\_\_ • Workpiece Weight: \_\_\_\_\_

D Center Hole Diameter: \_\_\_\_\_ • Concentricity to Achieve: \_\_\_\_\_

E Center: Live \_\_\_\_\_ Dead \_\_\_\_\_ • Maximum Tailstock Ability Force (lbs.): \_\_\_\_\_

**Please attach finished part print to this application data request sheet.**

## Operation

Maximum Depth of Cut: \_\_\_\_\_

Are there simultaneous operations?  Yes  No

Feed/Revolution: \_\_\_\_\_

Spindle rotation:

Cutting Speed (inch/rev.): \_\_\_\_\_

Clockwise  Counterclockwise  Both

RPM: \_\_\_\_\_

## Machine Data

Machine Type (check one):  Lathe  Mill  Hobber  Grinder  Other \_\_\_\_\_

Machine manufacturer: \_\_\_\_\_ Machine Model No: \_\_\_\_\_

Tailstock center:  Live  Dead

Tailstock center size:  3MT  4MT  5MT  Other \_\_\_\_\_

Maximum tailstock force available (lbs.): \_\_\_\_\_