

## Pipe Driver (Bore Driver)

- Full turning or grinding without unchucking
- Blades index in the event of scoring, doubling blade life
- Replacement blades are interchangeable within .005"
- Blades can be replaced or indexed without removing from machine
- Retainer lugs and slot depth provide excellent stiffness and rigidity under extreme feeds and speeds
- Torque limit on straight shanks prevents driver from slipping at breakaway/startup
- Crowned angles and flats designed to minimize impressions in bevels
- Material selection and heat treating are carefully monitored to maximize performance under demanding production conditions

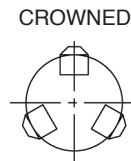
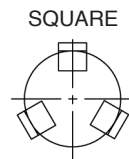
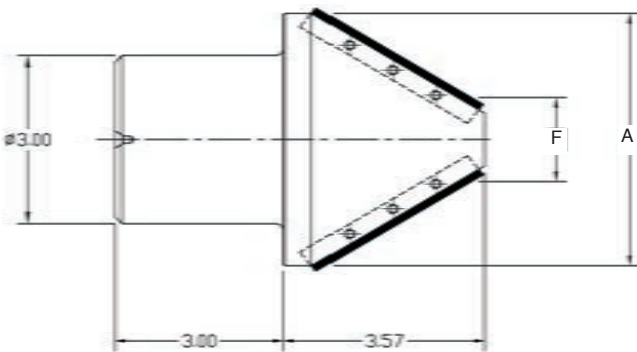

PIPE DRIVER			
Model	A	F	No. of Blades
PD045	4.50	1.50	3
PD075	7.50	4.50	5
PD105	10.50	7.50	7
PD135	13.50	10.50	9

Pipe Driver comes with two sets of crowned blades.

BLADES	
Model	Blade Style
BS100	Square
BC100	Crowned

## Spider Mandrels (Live or Dead)

- Precision incremental adjustments in thin wall bores
- Rotational accuracy of mandrels is .0002"
- Available with 3, 4, and 6 adjustment lugs
- Design of mandrel provides easy access to adjustment lugs
- Optional materials available for special design lugs
- Bull rings with extended lugs available to accommodate larger bores without changing the mandrel

