

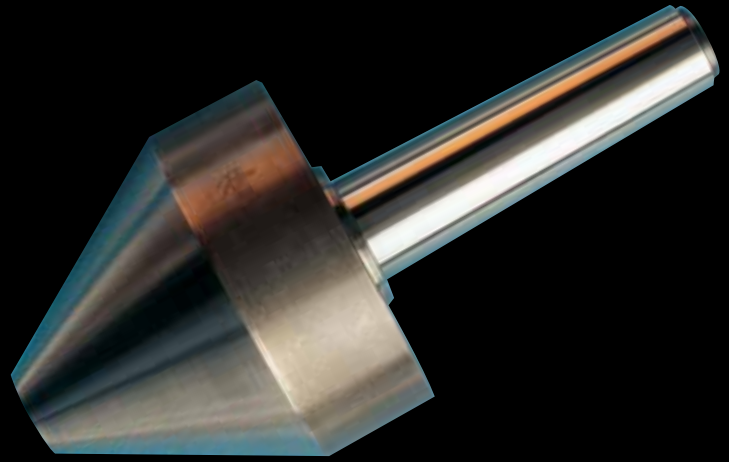

Bull Nose Live Centers

- Large workpiece center holes.
- Large piece parts.
- Riten full service and repair.



Riten Bull Nose Centers are designed for large bore, heavy work pieces such as hydraulic cylinders, thick wall pipe and heavy rolls. They utilize both ball and tapered roller bearings. For best results, choose a bull nose center that will place the workpiece in the middle or toward the larger end of the 60° angle. This will balance the weight of the part on the center and help carry the load evenly over the bearings.

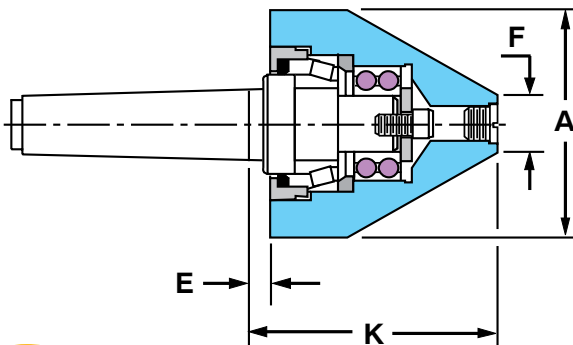

Accuracy guaranteed to $\pm .00015$

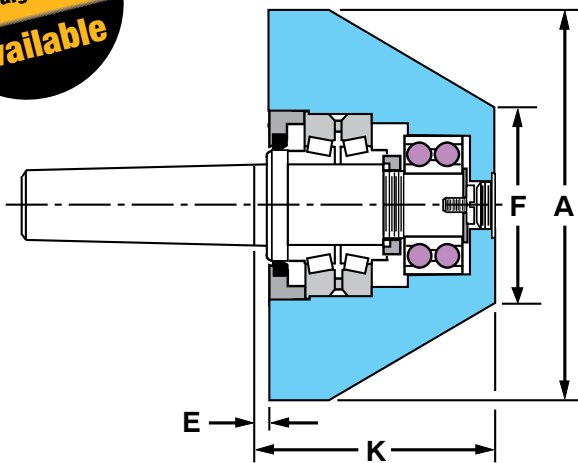

Accuracy guaranteed to $\pm .0002$

Jarno,
Brown & Sharpe,
and Straight Shanks
Available

MORSE TAPER						
Model	MT	A	F	E	K	W. P. Weight
56412	2	4.00	1.00	0.38	4.29	2000
56413	3	4.00	1.00	0.39	4.29	3800
56414	4	4.00	1.00	0.39	4.30	4800
56415	5	4.00	1.00	0.38	4.29	4800
56523	3	5.00	2.00	0.38	3.82	3800
56524	4	5.00	2.00	0.38	3.83	4800
56525	5	5.00	2.00	0.38	3.82	4800
56633	3	6.50	3.00	0.38	3.91	3800
56634	4	6.50	3.00	0.38	3.92	4800
56635	5	6.50	3.00	0.38	3.91	4800
56636	6	6.50	3.00	0.79	4.32	4800

MORSE TAPER						
Model	MT	A	F	E	K	W. P. Weight
56945	5	9.00	4.00	0.47	6.63	7000
56946	6	9.00	4.00	0.47	6.63	12000
56105	5	10.50	5.00	0.45	7.45	7000
56106	6	10.50	5.00	0.45	7.45	15000
56107	7	10.50	5.00	0.45	7.45	15000
56126	6	12.00	6.00	0.45	7.45	15000
56127	7	12.00	6.00	0.45	7.45	15000