

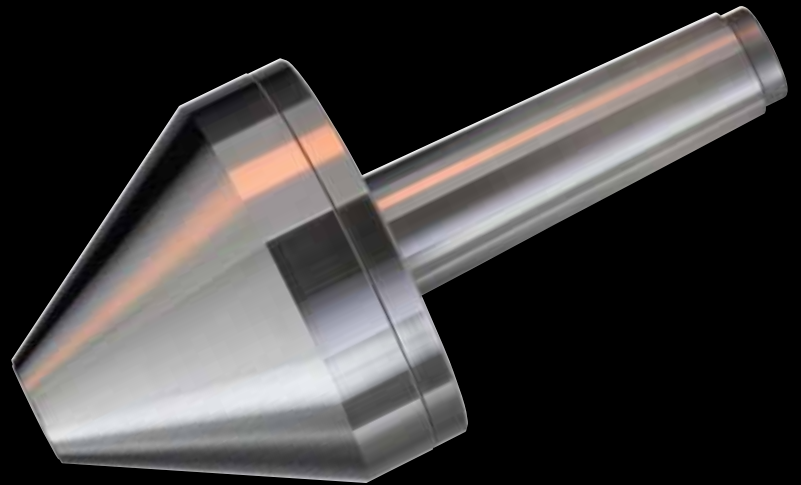

Precision Bull Nose Live Centers

- Accuracy guaranteed to $\pm .0001$.
- For heavy, large center hole workpieces.
- High RPM capacity.
- Riten full service and repair



Riten Precision Bull Nose Centers are engineered for precision grinding, threading and turning of heavy, large center hole work pieces. They provide greater accuracy and higher speeds than standard Bull Nose Centers. The rigidity of the center prevents vibration and chatter. For the best support and chatter-free parts, choose a center where the part will seat as close to the large diameter as possible.

Engineered for precision grinding, threading and turning of heavy, large center hole work pieces. For the best support and chatter-free parts, choose a center where the part will seat as close to the large diameter as possible.

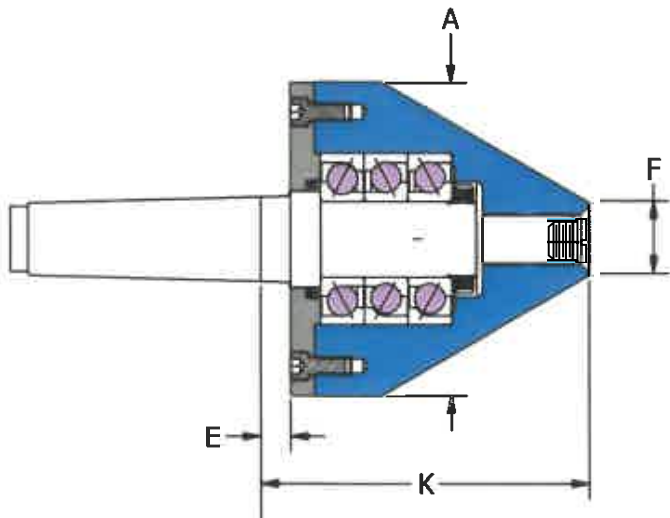

Accuracy guaranteed to $\pm .0001$



MORSE TAPER							
Model	MT	A	F	E	K	Max RP	W. P. Weight
56202	2	2.48	0.56	0.26	3.26	8500	1350
56203	3	2.48	0.56	0.38	3.38	8500	1350
56303	3	3.50	1.00	0.27	3.77	7000	2700
56304	4	3.50	1.00	0.26	3.76	7000	2700
56404	4	4.50	1.00	0.62	5.37	6000	4000
56405	5	4.50	1.00	0.62	5.37	6000	4000
56505	5	5.50	1.50	0.63	5.56	4500	7000
56506	6	5.50	1.50	0.63	5.56	4500	7000
56605	5	6.50	1.50	0.62	6.81	4000	10,000
56606	6	6.50	1.50	0.62	6.81	4000	10,000
56705	5	7.50	2.00	0.62	7.25	3000	15,000
56706	6	7.50	2.00	0.62	7.25	3000	15,000
56707	7	7.50	2.00	0.62	7.25	3000	15,000
56855	5	8.50	3.00	0.62	7.25	3000	15,000
56856	6	8.50	3.00	0.62	7.25	3000	15,000
56857	7	8.50	3.00	0.62	7.25	3000	15,000
56805	5	10.00	4.00	0.63	7.13	2800	19,000
56806	6	10.00	4.00	0.63	7.13	2800	19,000
56807	7	10.00	4.00	0.63	7.13	2800	19,000
56905	5	12.00	6.00	0.63	7.13	2800	19,000
56906	6	12.00	6.00	0.63	7.13	2800	19,000
56907	7	12.00	6.00	0.63	7.13	2800	19,000
56915	5	14.00	8.00	0.63	7.13	2800	19,000
56916	6	14.00	8.00	0.63	7.13	2800	19,000
56917	7	14.00	8.00	0.63	7.13	2800	19,000