



Engineered Products (cont.)

Replaceable Bell Head Live and Dead Centers

Dead Center Mandrels

- Heat treated for additional strength
- Accuracy guaranteed to $\pm .0001$ assembled

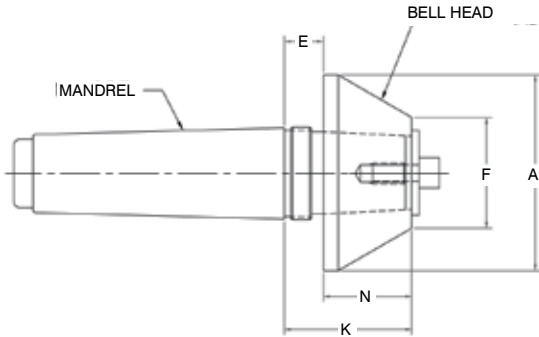

Live Center Mandrels

- Accuracy guaranteed to $\pm .0001$ assembled
- Riten full service and repair

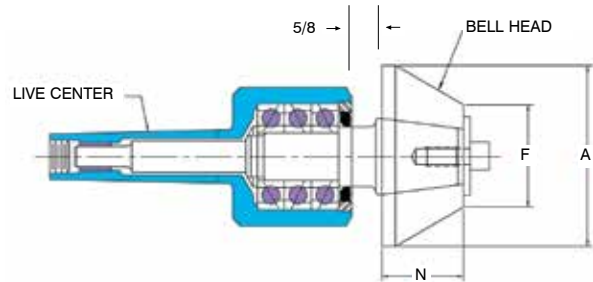

DEAD CENTER MANDRELS - MORSE TAPER

Model	MT	Threads	E	K	Bell Head
01104	4	-	0.50	2.19	Series 1
01114	4	M35 x 1.5	0.75	2.44	Series 1
01105	5	-	0.50	2.19	Series 1
01115	5	M45 x 1.5	0.75	2.44	Series 1
01195	5	-	0.75	2.71	Series 2
01185	5	M55 x 2.0	0.75	2.71	Series 2
01106	6	-	0.50	2.63	Series 2
01116	6	M55 x 2.0	0.75	2.88	Series 2
01117	7	M85 x 2.0	0.75	2.88	Series 2
01124*	4	M35 x 1.5	1.25	2.94	Series 1
01125*	5	M45 x 1.5	1.25	2.94	Series 1
01155*	5	M55 x 1.5	1.70	3.83	Series 2
01126*	6	3.00-12	2.35	4.48	Series 2

LIVE CENTERS - MORSE TAPER

Model	MT	Max. W. P. Weight	Bell Head
51403	3	730	Series 1
51404	4	1760	Series 1
51405	5	3520	Series 1
34405	5	6400	Series 2
34406	6	11,200	Series 2
34417	7	11,200	Series 2

Threaded mandrels include the extraction nut.

* Special taper for Mazak machines

BELL HEADS (Fit both live centers and mandrels)

Model	A	F	N	Bell Head
01375	3.75	2.12	1.69	Series 1
01525	5.25	3.62	1.69	Series 1
01675	6.75	5.12	1.69	Series 1
01825	8.25	6.62	1.69	Series 1
01975	9.75	8.12	1.69	Series 1

BELL HEADS (Fit both live centers and mandrels)

Model	A	F	N	Bell Head
02045	4.50	2.50	2.13	Series 2
02055	5.50	3.33	2.13	Series 2
02075	7.50	5.33	2.13	Series 2
02095	9.50	7.33	2.13	Series 2
02115	11.50	9.33	2.13	Series 2
02135	13.50	11.33	2.13	Series 2
02155	15.50	13.33	2.13	Series 2

All Bell Heads are heat treated for additional strength.

All Bell Heads include screw and washer.